

Variable Speed Drive



CFW 08
VECTOR INVERTER **Plus**



The WEG CFW 08 VSD series is intended for the speed control of three-phase induction motors. These VSD's incorporate the most advanced technology, and full features by their compactness and set of special functions available. WEG CFW-08 VSD's are easy to install and operate and are equipped with already optimized software that

can be easily set through a Keypad. This enables them to process and control industrial machine. In addition, the CFW 08 Plus series is equipped with dead time compensation techniques, thus avoiding motor instability and providing torque increase at low speeds.

Benefits







- DSP (Digital Signal Processor) control allows a reasonable improvement of the inverter performance
- State of the Art Technology
- Electronics with SMD components
- V/Hz or Sensorless Vector Control
- Sinusoidal PWM - *Space Vector Modulation*
- IGBT modules of last generation
- Quiet motor running
- Interface with touching membrane keypad
- Flexible programming
- Compact dimensions
- Easy installation and Operation
- High starting torque
- Kit for conduit installation

Main Applications

- Centrifugal pumps
- Process pumps
- Fans / Exhausts
- Stirrers / Mixers
- Extruding machines
- Conveyors
- Rollout tables
- Granulators / Peletizers
- Driers / rotating ovens
- Rotating filters
- Winders / Unwinders
- Cutting machines

CFW08 VARIABLE SPEED DRIVE

Models and optional Accessories

					
STANDARD	TCR-CFW08	MCS-CFW08 SERIAL INTERFACE MÓDULO	MIS-8R INTERFACE MÓDULO	KMD-CFW-08-M1	KN1-CFW08-MX
Standard model with HMI-CFW08-P (Human Machine Interface)	Optional model without HMI (with dummy cover)	Optional Kit: Serial Communication RS-232 (MCS-01)	Optional Kit: Interface for remote serial HMI (HMI-CFW08-S)	Optional Kit: Fastening base on DIN rails (only for Size 1)	Optional Kit: connection in metallic conduit (NEMA 1)

Remote Human-Machine Interface

Model with MIS-CFW08 and remote keypad (HMI)

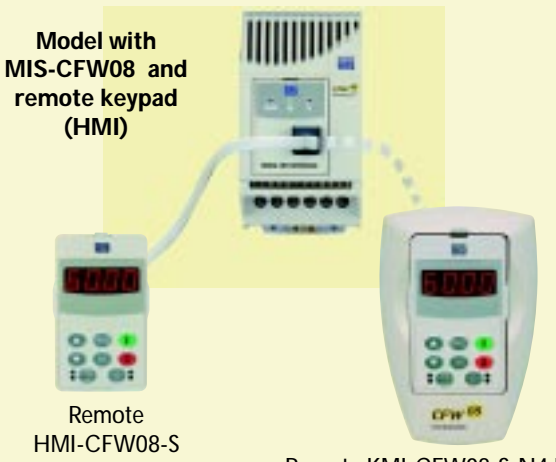

Remote HMI-CFW08-S for direct fastening (cables: 1 ... 10m)

Remote KMI-CFW08-S-N4 HMI with frame and NEMA 4 degree of protection (cables: 1 ... 10m)

Superdrive

Model with KCS-CFW08 serial communication Kit.

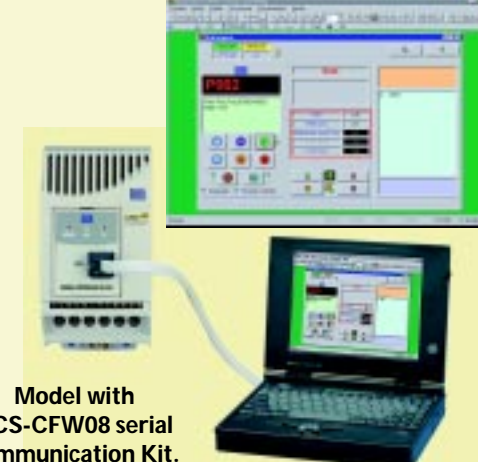

Programming Software via microcomputer PC in Windows ambient for parametrization, control and monitoring of CFW-08 VSD

Block Diagram

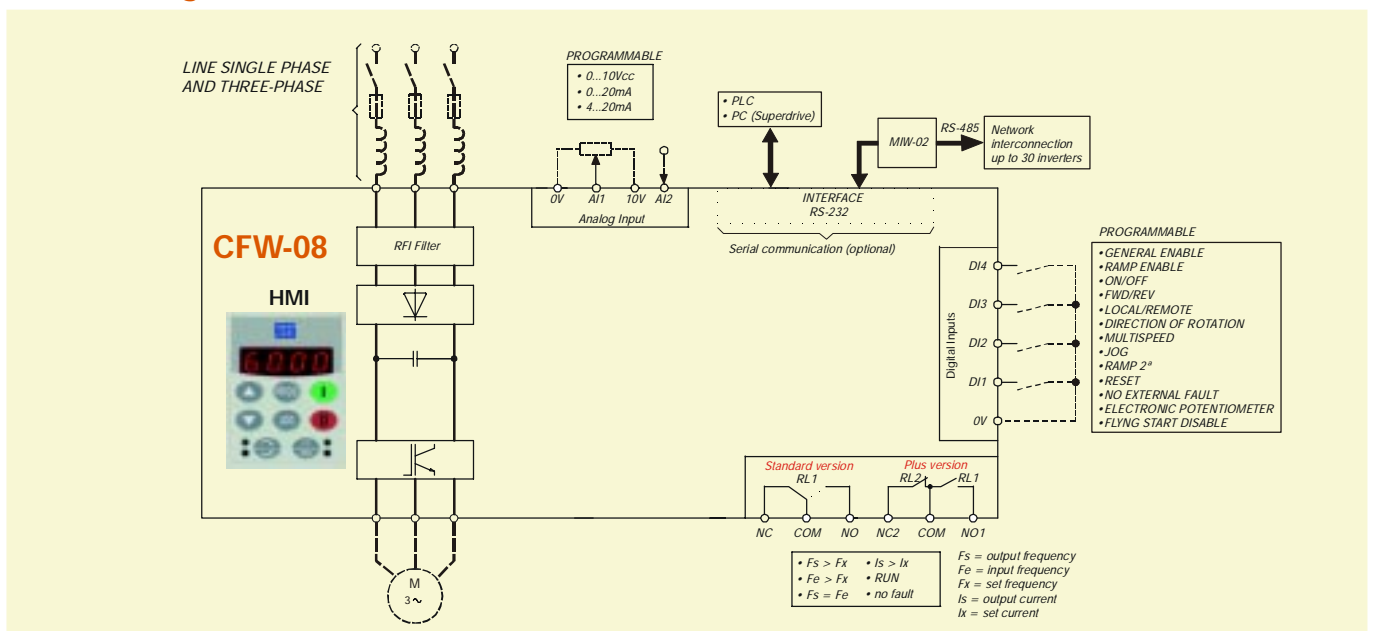

Specification Table

Line Voltage	CFW-08 VSD			MAX. RATED MOTOR POWER			Dimensions (mm)			Weight (kg)	
	Power Supply	Model	I nom (A)	Voltage (V)	Power		H	W	D		
					HP	kW					
200/220/230/240V	Single-phase or Three-phase	CFW080016B2024PSZ	1.6	220	0.25	0.18	151	75	131	1.0	
		CFW080026B2024PSZ	2.6		0.5	0.37					
		CFW080040B2024PSZ	4.0		1.0	0.75					
	Three-Phase	CFW080070T2024PSZ	7.0		2.0	1.5	200	115	150		2.0
	Single-phase or Three-phase	CFW080073B2024PSZ	7.3		2.0	1.5					
		CFW080100B2024PSZ	10		3.0	2.2					
	Three-Phase	CFW080160T2024PSZ	16		5.0	3.7					
380/400/415/440/460/480V	Three-Phase	CFW080010T3848PSZ	1.0	380	0.25	0.18	151	75	131	1.0	
		CFW080016T3848PSZ	1.6		0.5	0.37					
		CFW080026T3848PSZ	2.6		1.0	0.75					
		CFW080040T3848PSZ	4.0		2.0	1.5					
		CFW080027T3848PSZ	2.7		1.5	1.0	200	115	150		2.0
		CFW080043T3848PSZ	4.3		2.0	1.5					
		CFW080065T3848PSZ	6.5		3.0	2.2					
		CFW080100T3848PSZ	10		5.0	3.7					
	Three-Phase	CFW080010T3848PSZ	1.0	440	0.33	0.25				151	
		CFW080016T3848PSZ	1.6		0.75	0.55					
		CFW080026T3848PSZ	2.6		1.5	1.1					
		CFW080040T3848PSZ	4.0		2.0	1.5	200	115	150	2.0	
		CFW080027T3848PSZ	2.7		1.5	1.1					
		CFW080043T3848PSZ	4.3		2.0	1.5					
		CFW080065T3848PSZ	6.5		3.0	2.2					
		CFW080100T3848PSZ	10		5.0	3.7					

NOTES: 1) The maximum motor powers listed above were based on WEG II and IV-pole motors. For motor with different number of poles (ex.: VI and VIII-poles), other voltages (ex.: 230V, 400V and 460V) and/or motors from other manufacturers, specify the VSA through the rated motor current.

Coding

CFW-08	0040	B	2024	P	O	00	00	00	00	00	00	00	Z
1	2	3	4	5	6	7	8	9	10	11	12	13	14

1 CFW-08 Variable Speed Drive

2 Rated Output Current:

200-240 V		380-480 V	
0016	1.6 A	0010	1.0 A
0026	2.6 A	0016	1.6 A
0040	4.0 A	0026	2.6 A
0070	7.0 A	0027	2.7 A
0073	7.3 A	0040	4.0 A
0100	10 A	0043	4.3 A
0160	16 A	0065	6.5 A
		0100	10 A
		0130	13 A
		0160	16 A

3 Number of Phase

S = single-phase
T = three-phase
B = single-phase or three-phase

4 Power supply
2024 = 200-240 V
3848 = 380-480 V

5 Manual Language
P = Portuguese
E = English
S = Spanish
G = German

6 Options
S = standard
O = with options

7 Enclosure
00 = standard
N1 = Nema 1

8 Huma-Machine Interface
00 = standard
SI = without interface

9 Dynamic Braking
00 = standard
DB = dynamic braking (Built-in IGBT)

10 Control board
00 = standard
A1 = control 1 (plus)

11 EMI filter
00 = without filter
FA = Built-in Class A filter

12 Special Hardware
00 = not provided
Hx = special Hardware in version X

13 Software Especial
00 = not provided
Hx = special Hardware in version X

14 End code

Ex.: CFW080040B2024EOA1Z

VSD of CFW-08 series, 4.0 A, single-phase or three-phase at 200-240 Vac, manual in English and Plus control board.

Technical Data

Model		Standard CFW-08	CFW-08 Plus	
POWER SUPPLY	Voltage	Single-Phase	200 - 240V: 200 / 220 / 230 / 240 V (+10%, -15%)	
		Three-Phase	200 - 240V: 200 / 220 / 230 / 240 V (+10%, -15%)	
	Frequency		380 - 480V: 380 / 400 / 415 / 440 / 460 / 480 V (+10%, -15%)	
	Cos φ (Displacement Factor)		50 / 60 Hz +/- 2 Hz (48 ... 62 Hz)	
ENCLOSURE	Standard	> 0,98		
	Optional	IP 20		
CONTROL	Power Supply Type	NEMA 1 with additional kit for metallic conduit connection		
	Control Method	Switching power supply		
	Control Type	DSP (Digital Signal Processor), 16 bits, sinusoidal PWM (<i>Space Vector Modulation</i>)		
			Imposed voltage - linear V/Hz or quadratic (scalar)	
			VVC: <i>Voltage Vector Control</i>	
	Suitching Frequency	IGBT Transistors IGBT – Frequencies : 2.5 / 5.0 / 10 / 15 kHz		
	Frequency Range	0 ... 300 Hz		
	Frequency Resolution	Analog Ref.: 0.1% of Fmax. and digital Ref.: 0.01 Hz (f<100Hz); 0.1Hz (f>100Hz)		
	Accuracy (25°C ± 10°C)	Analog Ref.: 0.5% and digital Ref.: 0.01%		
Overload capacity	150% during 60 sec. every 10 min. (1.5 x Rated Current.)			
Efficiency	>95%			
INPUTS	Analog	1 isolated input 0...10 V. 0...20 mA or 4...20 mA	2 isolated inputs 0...10 V, 0...20 mA ou 4...20 mA	
	Digital	4 programmable isolated inputs		
OUTPUTS	Relay	1 programmable output, reversal contact I (NO/NC)	2 programmable outputs, 1 NO and 1 NC	
	Analog	Programming options: Is > Ix ; Fs > Fx ; Fe > Fx ; Fs = Fe ; Run		
COMMUNICA-TION	Serial Interface	- 1 Isolated analog output 0 - 10 V (8 bits)		
	"Field Bus" Networks	RS-232 or RS-485 (optional)		
SAFETY	Protections	Unit for ProfiBus DP Communication, DeviceNet or ModBus (optional)		
		DC ling overvoltage / undervoltage		
		Overtemperature		
		Output overcurrent		
		Motor overload (i x t)		
		Hardware fault, external fault and serial communication error		
		Short-circuit at output and short-circuit at output between phase-ground		
		Programming fault and self-tuning error		
HUMAN-MACHINE INTERFACE (HMI)	Commands	On/Off , Parameter Setting (Programming of special functions)		
		Frequency Increment / Decrement (Speed)		
		JOG, Reversal of Direction of Rotation and Local /Remote Selection		
	Monitoring (Reading)	Motor Output Frequency (Hz)		
		DC Link Voltage (V)		
		Value proportional to the frequency (Ex.:RPM)		
		Heat Sink Temperature		
		Motor Output Current (A)		
		Motor Output Voltage (V)		
		Error / Fault Messages		
Load Torque				
AMBIENT	Temperature	0 ... 40 °C (up to 50 °C with output current derating (2% / °C)		
	Humidit	5 ... 90% non condensing		
	Altitude	0 ... 1000 m (up tp 4000 m with output current derating (10% / 1000 m)		
FINISHING	Color	Light gray – PANTONE – 413 C		
CONFORMITIES	Electromagnetic Compatibility	EMC directive 89 / 336 / EEC – Industrial Environment		
		EN 61800-3 Standard (EMC - Electromagnetic Compatibility)		
	Low Voltage	LVD 73/23/EEC - Low Voltage Directive / UL 508C		

Resources / Special Functions

Standard / Plus
Incorporated Human-Machine Interface - 7 segment LED
Programming enabling password
Fault self-diagnosis and Auto-Reset
Specific value indication (programmable) - (Ex.: m/min; rpm, etc)
Slip compensation
Manual and automatic I x R
Programmable V/Hz Curve
JOG Function (transitory speed pulses)
COPY Function via remote keypad (HMI-CFW08-S)
Linear and 'S'type ramp and double ramp
Acceleration and deceleration ramps (independent)
DC braking (DC Current)
Multi-Speed Function (up to 8 pre-programmable speeds)
FWD/REV Selection
Local/Remote Operation selection
Overposed PID Regulator (automatic level, pressure control, etc)
Starting with running motor (<i>Flying Start</i>)
Rejection of critical or resonant frequencies (<i>Skip Frequency</i>)
Operation during transitory line faults (<i>Ridethru</i>)

Optional		
Remote Keypad (HMI) (7 segment LED)	HMI-CFW08-S	
Remote Keypad (HMI) (IP 55 Enclosure)	HMI-CFW08-IN4-S	
Interface Module for remote keypad (HMI)	MIS-CFW08	
Interconnection cable of the remote HMI (1 ; 2 ; 3 ; 5 ; 7,5 and 10 m)	CAB-HMI08-S-X	
Serial Communication module RS-232	MCS-CFW08	
RS-232 to RS-485 converter (MCS-CFW08 Module required)	MIW-02	
Programming Software via microcomputer PC	SUPERDRIVE	
NEMA 1 Kit for metallic conduit connection	KN1-CFW08-MX	
Kit for assembling on DIN rail	KMD-CFW08	
Frame Kit moldura for HMI-CFW08-S	KMR-CFW08-S	
Units for Fieldbus Communication Networks	ProfiBus DP	MFW-01 / PD
	DeviceNet	MFW-01 / DN
	ModBus RTU built-in	-
EMC Filter with high Attenuation Capacity - Class A - internal	-	
EMC Filter with high Attenuation Capacity -Class B - external	-	

Distributor



WEG EXPORTADORA
 Av. Prefeito Waldemar Grubba, 3000
 89256-900 - Jaraguá do Sul - SC - Brazil
 Phone: 55 47 372-4000 - FAX 55 47 372-4060
www.weg.com.br