

- All alarm indications according to DIN VDE 0107
- Integration into the MEDICS system via RS485 bus easy-to-clean front foil
- LC text display
- RS485 bus to connect several MK2418, mutual monitoring
- native language selection
- casings suitable for surface mounting, flush mounting and cable-duct mounting
- all contact circuits comply with the requirements of protective separation according to prEN 50178
- Test button for local operation

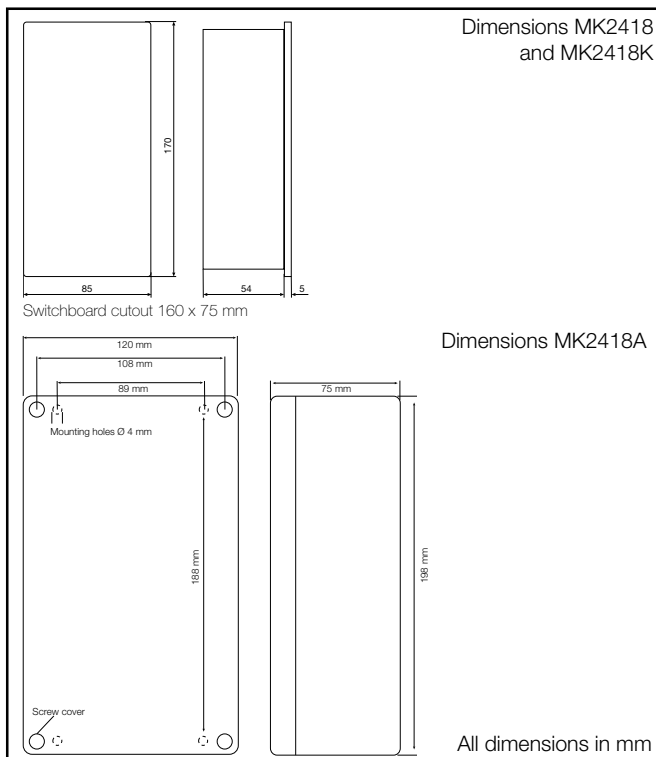

Application

MK2418 is a remote alarm indicator and test combination for medically used rooms to indicate the operating and alarm conditions of monitoring devices according to the requirements of DIN VDE 0107. MK2418 can also be used for the indication of BENDER systems with RS485 interface and BMS protocol (MEDICS, EDS- and RCMS systems), for BENDER automatic switchover units and for single BENDER monitoring devices.

The following versions are available:

- MK2418-11 Alarm and test combination with 8 digital inputs and 1 analog input suitable for connection to insulation monitoring devices. Including a relay to test the insulation monitoring device (PT1/PT2) and a relay for collective fault alarm. Flush-mounting type.
- MK2418-12 Alarm and test combination without inputs. Flush-mounting type.
- MK2418A-11 Identical with MK2418-11, but suitable for surface mounting.
- MK2418A-12 Identical with MK2418-12, but suitable for surface mounting.
- MK2418K-11 Identical with MK2418-11, but suitable for cable-duct mounting.
- MK2418K-12 Identical with MK2418-12, but suitable for cable-duct mounting.

RS485 bus

The MK2418 indicates alarm- and status messages which come from nodes of the RS485 network. The coordination which message of which node shall be indicated ensues via the ALARM ADDRESS menu (see page 2.2/6.4).

If two or more MK2418 are used, the alarm and test combinations can monitor each other during operation. If one of the MK2418 fails, it will be indicated by the other one (ones).

Several MK2418 can be connected together to one network via the RS485 bus. If more than two MK2418 are to be connected, address settings at each MK2418 will be necessary. For information about the design of such a system and the setting refer to the operating manual MK2418 (TGH 1272).

Standard settings

Using the MK2418 within different applications makes it necessary to doublecheck the default settings. In most cases the settings of address, alarm address and test address have to be changed. Please see table APPLICATIONS on page 2.2/6.3 of this sheet and study the manual of the corresponding BENDER system (MEDICS, EDS470, RCMS470).

Caution: not changing the parameters according your individual application will result in error messages and buzzer alarms.

Important:

Always check if the settings of MK2418 are suitable for your individual application.

Factory settings of the inputs:

- IN1 ... IN5 : N/C operation
- IN6 ... IN8 : N/O operation

Note:

Inputs which are not assigned being in N/C operation will cause an alarm indication. For that reason, it is necessary to change these inputs from 0 V to 24 V (see menus).

Technical data

| | |
|---------------------------------|----------------------|
| Supply voltage | AC 40 ... 60 Hz 24 V |
| Operating range, supply voltage | 20 ... 28 V |
| Max. power consumption | 150 mA |

Inputs/outputs

| | |
|--|----------------------------|
| Digital inputs (only MK2418-11) | 8 (IN1 ... IN8) |
| Voltage range (high/low) | min. 15 V / max. 2 V AC/DC |
| All digital inputs with electrical isolation | |
| Analog inputs (only MK2418-11) | 1 (M+/M-) |
| Contact circuit for test button (only MK2418-11) | PT1/PT2 |
| Interface | RS485 |

Alarm relay

| | |
|--|-----------------------|
| Contact circuit with protective separation | |
| Switching components | 1 change-over contact |
| Rated contact voltage | AC 250 V/DC 300 V |
| Making capacity | UC 5 A |
| Breaking capacity at 230 V and cos phi=0.4 | AC 2 A |
| at DC 220 V and L/R=0.04s | DC 0.2 A |
| Admissible number of operations | 12000 |
| Operating principle | N/C operation |

| | |
|--|--------------------------|
| Immunity against electromagnetic interferences acc. to EN 50 082-2 | |
| Emissions acc. to EN 55 011/CISPR11 | class B * |
| Ambient temperature, during operation | -5°C ... +55°C |
| Storage temperature range | -25°C ... +60 °C |
| Cross sectional area of the upper terminal strip | max 1.5 mm ² |
| Cross sectional area of the lower terminal strip | max. 2.5 mm ² |
| Protection class built-in components/terminals | IP50 / IP20 |
| Weight | approx. 330 g |

Legend to wiring diagrams

| | |
|--------------------------|---|
| 107TL47 | Insulation monitoring device. One MK2418 is supplied by the built-in signal voltage transformer. |
| AN470 | Additional transformer to supply a maximum of 4 MK2418. |
| LSE470 | Load monitoring relay to indicate overload and overtemperature. |
| SUA470 | Voltage relay to monitor the first main feeder. |
| K3 | Auxiliary relay of the switch-over system. Signals failure of the second feeder. |
| Isometer operating lamps | Optional insulation monitoring device for the operating lamps circuit, e.g. 107TL47-1. |
| System monitoring | Optional evaluation of system faults. |
| R | Terminating resistors 120 Ω of the RS485 bus. The RS485 bus must be terminated at the beginning and at the end. |

Note:

This description applies to the use and connection of MK2418 in combination with BENDER standard components integrated in a single-phase switch-over system UM107ET.

If MK2418 is used in combination with other switch-over system, it may be necessary to change the circuit arrangement. In this case, please contact your specialist at BENDER.

Accessories:

The converter SMI470-9 is available to convert the analog and digital alarm indications of the respective switch-over equipment UM... into an RS485 protocol.

* Class B devices are suitable for household and industrial use.

Wiring diagrams

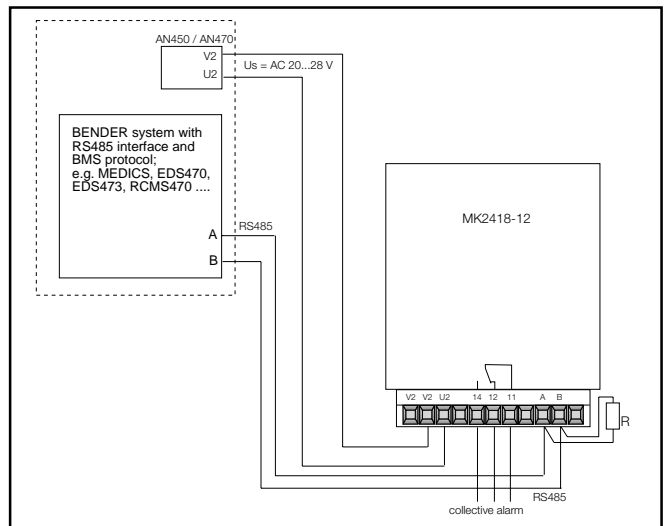

MK2418-12 connected to a BENDER system via RS485 bus with BMS protocol.

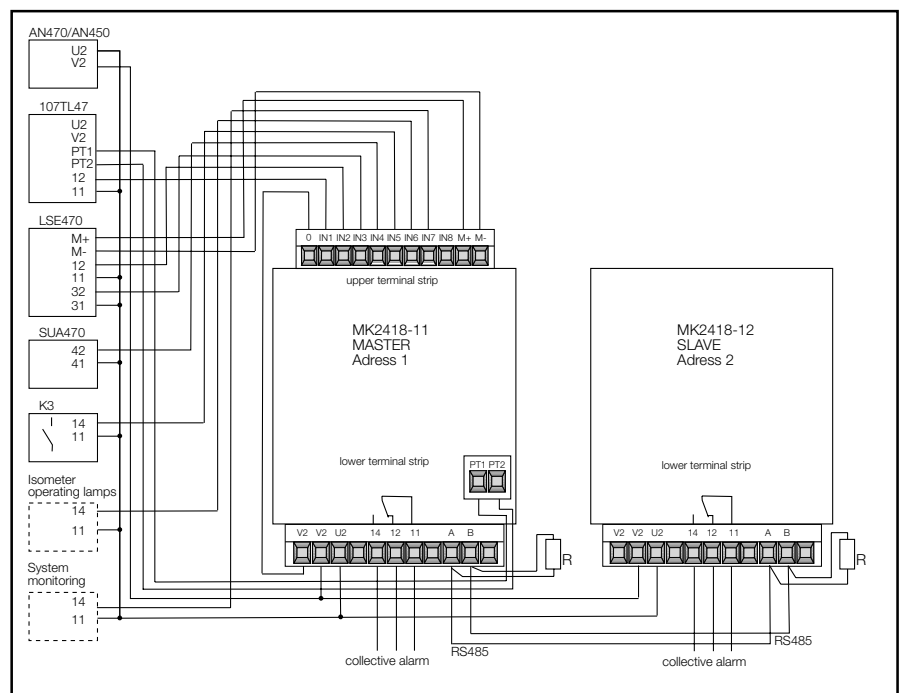

MK2418-11 and MK2418-12 as parallel indication in combination with BENDER standard components.

Ordering details:

| Type | Art. No. |
|------------|----------|
| MK2418-11 | 923 759 |
| MK2418K-11 | 923 762 |
| MK2418A-11 | 923 765 |
| MK2418-12 | 923 761 |
| MK2418K-12 | 923 763 |
| MK2418A-12 | 923 766 |

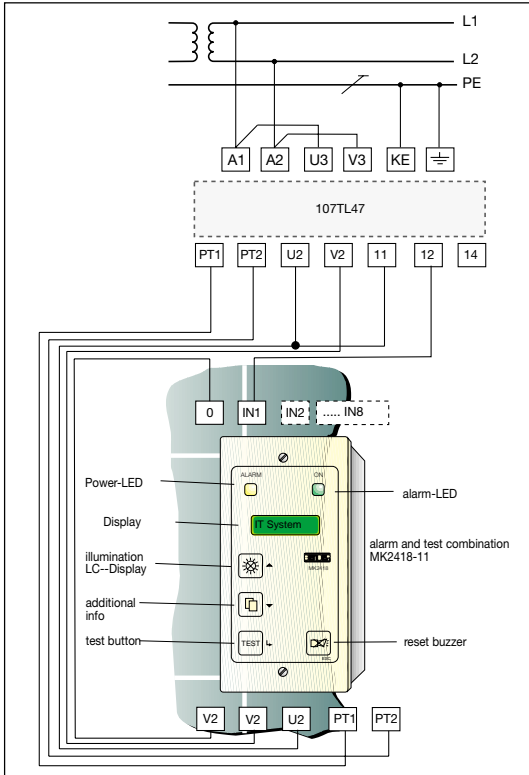

MK2418-11 connected as a single indication to an insulation monitor 107TL47. No RS485 bus connection.

Connecting cables

Interface cable A/B: JY(ST)Y 0.6 mm , shield single-ended connection to ground, max. length of the bus 1200 m

Digital inputs IN1 ... IN8: 0.8 mm², max. 500 m

Analog inputs M+/M-: 0.8 mm², max. 500 m

Max. length of the power supply cable U2/V2 in case of:

a) power supply from insulation monitoring device 107TL47

| Cross sectional area of connecting cable | max. cable length |
|--|-------------------|
| 0.8 mm ² | 150 m |
| 1.5 mm ² | 300 m |
| 2.5 mm ² | 450 m |

b) power supply from signal voltage transformer AN470

| Cross sectional area of connecting cable | 1 MK2418 | 2 MK2418 | 3 MK2418 | 4 MK2418 |
|--|----------|----------|----------|----------|
| 0.8 mm ² | 750 m | 400 m | 150 m | 50 m |
| 1.5 mm ² | 1500 m | 700 m | 250 m | 75 m |
| 2.5 mm ² | 2300 m | 1200 m | 400 m | 150 m |

The max. length of the connecting cables are indicated from U2/V2 of the AN470 up to U2/V2 of the last MK2418.

Examples of MK2418 parameter settings for different applications:

| Use of MK2418 with: | MK2418 address | MK2418 alarm address | MK2418 test address | Remark |
|---|------------------------------|---|---------------------|---|
| MEDICS: UMC107E... with default settings | 1 | 3+4 | 3 | use MK2418-12 |
| MEDICS: UMC107D... with default settings | 1 | 4 | 0 | use MK2418-12 |
| UM107ETU with 2 MK2418 | MK2418-11: 1 MK2418-12: 2 | MK2418-11: 2 MK2418-12: 1 | 0 | Mk2418-11 is MASTER, MK2418-12 is SLAVE. |
| 107TD47 | 1 | 3 | 3 | use MK2418-12 |
| EDS470 System | 2 30 | addresses of all EDS470-12 or EDS473-12 | no function | Set always unique addresses. Wrong and double addresses will result in malfunction, bus errors and buzzer alarms. |
| 107TL47 with single MK2418 | 1 | 0 | 0 | Use MK2418-11 |
| 107TL47 with 2 MK2418 as parallel indications | MK2418-11: 1 MK2418-12: 2 | MK2418-11: 2 MK2418-12: 1 | 0 | Use MK2418-11 plus MK2418-12 |

Factory settings:

MK2418-11

| | |
|---------------------------------------|------------|
| Address 1 (makes the MK2418 a MASTER) | |
| Language | German (D) |
| Test address | 0 |
| Alarm addresses | OFF |
| Person | TECH |
| S.-Quit | ON |
| Digital input IN1 | 0 V |
| Digital input IN2 | 0 V |
| Digital input IN3 | 0 V |
| Digital input IN4 | 0 V |
| Digital input IN5 | 0 V |
| Digital input IN6 | 24 V |
| Digital input IN7 | 24 V |
| Digital input IN8 | 24 V |

MK2418-12:

| | |
|--------------------------------------|------------|
| Address 2 (makes the MK2418 a SLAVE) | |
| Language | German (D) |
| Test address | 0 |
| Alarm addresses | OFF |
| Person | TECH |
| S.-Quit | ON |

Caution: Wrong parameter settings of MK2418 will result in malfunction, bus errors and buzzer alarms.

MK2418 Programming

Quick reference

The main menu:



- 1. EXIT Leave menu system or submenu
- 2. SETUP Set parameters for MK2418
- 3. ALARM ADDRESS Select the addresses of devices from which the alarm messages are to be indicated on this MK2418
- 4. SETUP INPUT Set options for digital inputs IN1...IN8
- 5. INFO Information about this MK2418

The setup submenu:

- 1. EXIT Leave or submenu
- 2. ADDRESS Set address of this MK2418
- 3. LANGUAGE Set the language of this MK2418
- 4. TEST ADDRESS Set the address of the insulation monitoring device which shall carry out a test when pressing the TEST button on this MK2418
- 5. PERSON Set the kind of indication
- 6. S.-QUIT Set wheather a common reset shall be possible or not

For all menus: confirm selection with , quit menu with **ESC**. Time out: after 15 s idle time the menu disappears.

Setting the parameters via software menus:

To activate menu press - and -key simultaneously for min. 3 sec.

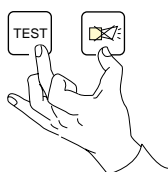

min. 3 sec

When the menu appears release both keys. Navigation through the menus and changing settings is easy: scroll with arrow keys (UP, DOWN key)

to the submenu you want to modify. Confirm selection with ENTER key. The cursor now jumps to the selected submenu or to the parameter position. Scroll through the parameters with arrow keys (UP, DOWN keys). Confirm the parameter with ENTER key. Leave the menu system by pressing the ESC key or via the EXIT menu.

Submenu SETUP



2. Setting address:



to select a unique address for this MK2418. Range: address 1 ... 30.

Note: MK2418 with address 1 is always MASTER; MK2418 with address 2...30 is SLAVE.

3. Selecting language:



to choose the language of the messages for this MK2418. Select your language from a list according international country codes e.g. D for German, GB for English. Default: German.

Selections:

| | | | |
|-----------|----|------------|-----|
| Czech | CS | Italian | I |
| Denish | DK | Polish | PL |
| Dutch | NL | Portuguese | P |
| English | GB | Norwegian | N |
| Finnish | SF | Slowene | SLO |
| French | F | Spanish | E |
| German | D | Swedish | S |
| Hungarian | H | | |

4. Setting test address:

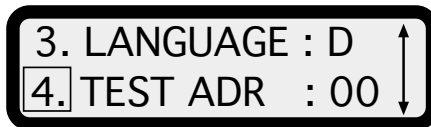

set the address of the insulation monitoring device (IMD) which shall carry out the test when the TEST key is pressed on this MK2418. Default: 0 (all address).

5. Setting kind of indications:



choose whether the alarm messages are for medical or for technical staff. Default: Techn.

6. Setting common reset:

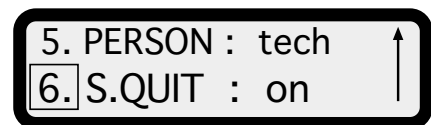

set whether the buzzer of this MK2418 is muted by a reset button of another MK2418 or tableau. Default: ON, common reset is activated. Setting: OFF, common reset is deactivated.

Submenu ALARM ADDRESS

2. Setting the alarm addresses:

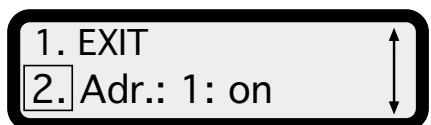

select those addresses whose alarm messages are to be indicated on this MK2418. Default: all OFF.

Note: all devices assigned to each other via the alarm addresses are mutually monitored. If one of the assigned devices fails, this is indicated on the remaining unit.

Submenu SETUP INPUT

2. Setting the mode of the digital inputs:

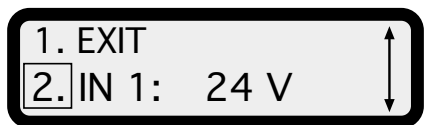

to set the mode of each digital input IN1...IN8. Setting to 24 V: alarm when a voltage of 24 V is applied across the respective input.

Setting to 0 V: alarm when no voltage is applied across the respective input.

Caution: Unassigned digital inputs which are set to 0 V will cause an alarm. Change setting of those inputs to 24 V.

Defaults:

| | |
|-------------------|------|
| Digital input IN1 | 0 V |
| Digital input IN2 | 0 V |
| Digital input IN3 | 0 V |
| Digital input IN4 | 0 V |
| Digital input IN5 | 0 V |
| Digital input IN6 | 24 V |
| Digital input IN7 | 24 V |
| Digital input IN8 | 24 V |

Submenu INFO

2. Information about device and firmware:

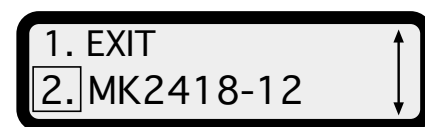

gives information about this device, its firmware, the address and the last update.

Factory settings:

MK2418-11

Address 1 (makes the MK2418 a MASTER)

| | |
|-------------------|------------|
| Language | German (D) |
| Test address | 0 |
| Alarm addresses | OFF |
| Person | TECH |
| S.-Quit | ON |
| Digital input IN1 | 0 V |
| Digital input IN2 | 0 V |
| Digital input IN3 | 0 V |
| Digital input IN4 | 0 V |
| Digital input IN5 | 0 V |
| Digital input IN6 | 24 V |
| Digital input IN7 | 24 V |
| Digital input IN8 | 24 V |

MK2418-12:

Address 2 (makes the MK2418 a SLAVE)

| | |
|-----------------|------------|
| Language | German (D) |
| Test address | 0 |
| Alarm addresses | OFF |
| Person | TECH |
| S.-Quit | ON |

For further information please refer to the operating manual for MK2418 (TGH 1272).

Important:

Always check if the default settings are suitable for your individual application. It may be necessary to change address, alarm addresses, the mode of the digital inputs or other parameters.

Example:

Mk2418-12 connected to a MEDICS automatic switchover unit UMC107E:

| | |
|------------------|---------|
| address: | 1 |
| alarm addresses: | 3 and 4 |
| test address: | 3 |